

CLIENT
CONFIDENTIAL

LOCATION:
New York

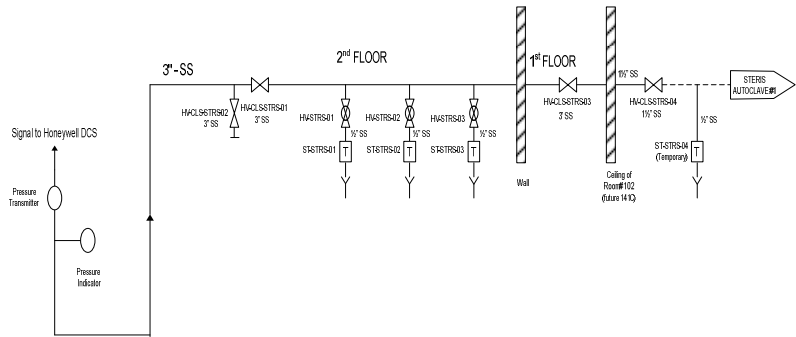

Clean Steam System Tie-In for New Steris

PROJECT START:
2008

PROJECT COMPLETE:
2008

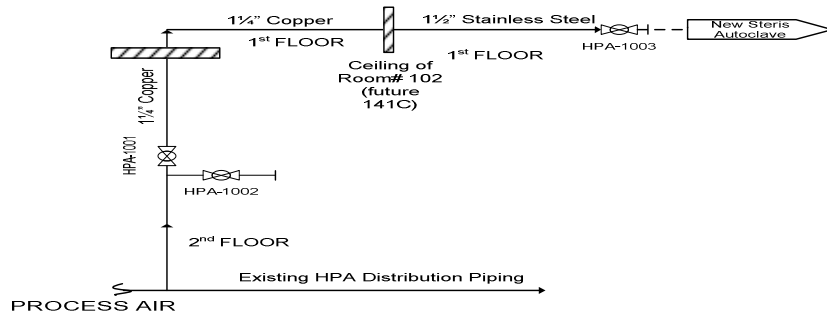

Process Air Tie-In for new Steris Autoclave Project

SCOPE OF WORK

IQ, OQ & PQ For Utilities Tie-Ins for Steris Autoclave

PROJECT DESCRIPTION

A new Autoclave room was built for the new Steris Autoclave which required the existing utilities to be connected to this new Autoclave. The utilities tie-in for the new autoclave included modifications to the existing Process Air system, HVAC system and Clean Stem. A&J provided validation services and qualified all the tie-in work to incorporate future use of the autoclave.

The Qualification and the utilities tie-in included the following:

- Installation and Operational Qualification of the Process Air Tie-In to the new Steris Autoclave
- Performance Qualification of the Process Air Tie-In to new Steris Autoclave
- Installation and Operational Qualification of the Clean Steam system modifications
- Performance Qualification of the Clean Steam system modifications.
- Installation and Operational Qualification for HVAC Ductwork Tie-in